

NOTES:

1. ALL DIMENSIONS ARE SHOWN FOR REFERENCE ONLY.
2. WEIGHT: 2.4 OZ (ZINC)
3. TORQUE TO 50 - 75 IN-LBS.

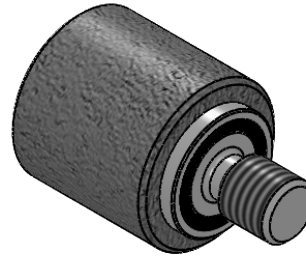

REVISIONS			
REV.	DESCRIPTION	DATE	APP.
A	PRELIMINARY RELEASE FOR REVIEW	03/16/17	BD

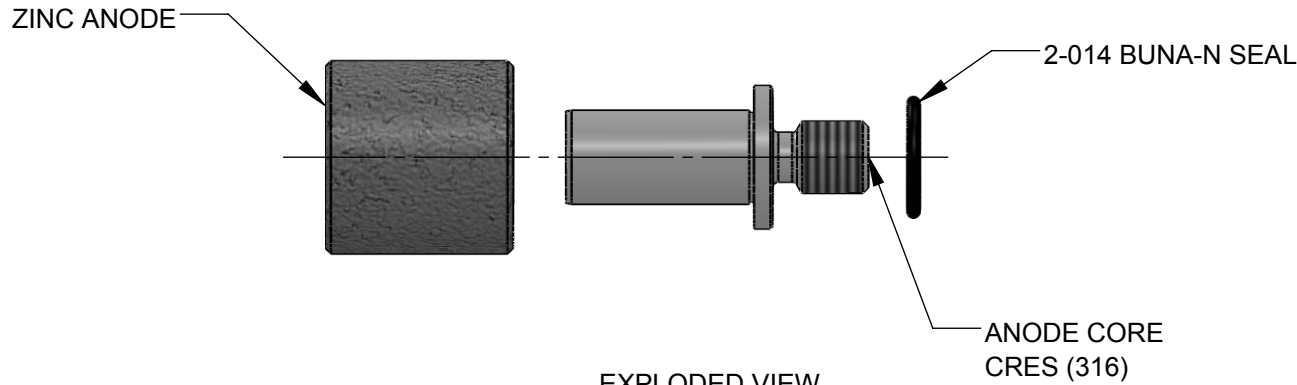
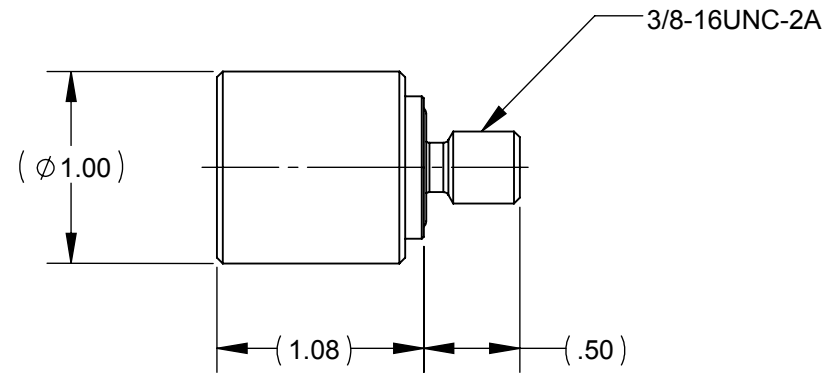
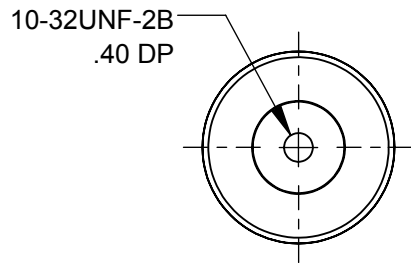

EXPLODED VIEW

<p><b>PROPRIETARY NOTE</b> All data and information contained or disclosed by this document is confidential and proprietary information of <b>PREVCO Subsea LLC</b> and all rights therein are expressly reserved. By accepting this material the recipient agrees that the material and the information therein is held in confidence and in trust and will not be used, copied, reproduced in whole or in part, nor its content revealed in any manner to others, except to meet the specific purpose for which it was delivered.</p>	TOLERANCES UNLESS NOTED				<p><b>PREVCO SUBSEA LLC</b></p>		<p>DRAWING TITLE <b>SMALL DIA ZINCOID WITH 3/8-16 THD - OUTLINE DRAWING</b></p>			
	.X ±.050	.XX ±.010	.XXX ±.003	ANGLES ±.5°					PROJECT INVENTORY	MODEL NO. PREFIX N/A
	CONCENTRICITY .004 TIR				CAGE CODE:	1PV08	In-Air Weight Est. (lbs):	DRAWING NO. <b>03197-001</b>		
	PRIMARY UNITS ARE INCHES				DRAWN BY:	MAD	APPR. BY:	BD	DRAWN DATE: 03/16/17	SHEET 1 of 1