

NOTES, UNLESS OTHERWISE SPECIFIED:

1. ALL EXTERIOR DIMENSIONS ARE NOMINAL AND SHOWN FOR REFERENCE ONLY.
2. ALL EXPOSED MATERIAL: TITANIUM, GRADE 5 (DOMESTIC).
3. FINISH: 1. TIODIZE OR EQUIVALENT COATING - 001
2. NO COATING - 001NT
4. ALL SEALS AND MOVING PARTS IN THIS PRESSURE RELIEF VALVE ARE SERIALLY REDUNDANT.
5. RATED FOR 6,000M OPERATING DEPTH.
6. FACTORY SET CRACKING PRESSURE: 10-15 PSI. (4.5-7 PSI IN DEGRADED MODE).
7. TORQUE TO 55-75 INCH LBS.

REVISIONS			
REV.	DESCRIPTION	DATE	APP.
A	INITIAL RELEASE	08/28/18	BD
B	CHANGED NOTE 3 - SHT 1	01/17/19	BD



PREVCO SUBSEA DUAL POPPET PRESSURE RELIEF VALVE

<p>PROPRIETARY NOTE</p> <p>All data and information contained or disclosed by this document is confidential and proprietary information of PREVCO Subsea LLC and all rights therein are expressly reserved. By accepting this material the recipient agrees that the material and the information therein is held in confidence and in trust and will not be used, copied, reproduced in whole or in part, nor its content revealed in any manner to others, except to meet the specific purpose for which it was delivered.</p>	TOLERANCES UNLESS NOTED				PREVCO SUBSEA LLC		DRAWING TITLE DUAL POPPET PRESSURE RELIEF VALVE ICD	
	.X	.XX	.XXX	ANGLES	PROJECT	MODEL NO. PREFIX	DRAWING NO. 03629-001	
	±.050	±.010	±.003	±.5°	STD PRODUCT	DUAL POPPET PRV - VPA		
	CONCENTRICITY .004 TIR				CAGE CODE: 1PV08		DRAWN DATE: 08/28/18 SHEET 1 of 3 REV. B	
PRIMARY UNITS ARE INCHES				DRAWN BY: MAD	APPR. BY: BD			

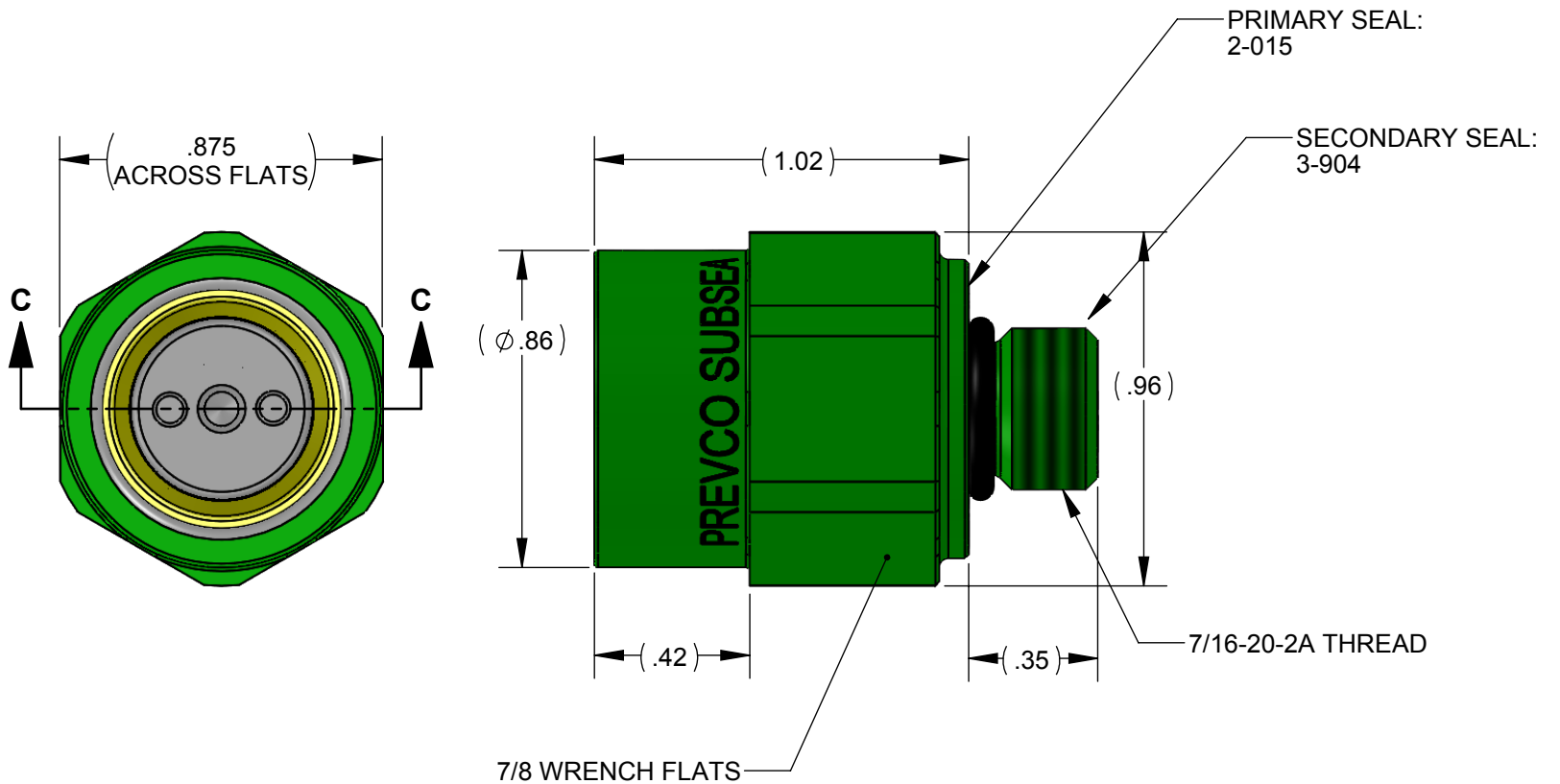

PROPRIETARY NOTE
 All data and information contained or disclosed by this document is confidential and proprietary information of **PREVCO Subsea LLC** and all rights therein are expressly reserved. By accepting this material the recipient agrees that the material and the information therein is held in confidence and in trust and will not be used, copied, reproduced in whole or in part, nor its content revealed in any manner to others, except to meet the specific purpose for which it was delivered.

TOLERANCES UNLESS NOTED			
.X	.XX	.XXX	ANGLES
±.050	±.010	±.003	±.5°
CONCENTRICITY .004 TIR			
PRIMARY UNITS ARE INCHES			

PREVCO SUBSEA LLC	
PROJECT	MODEL NO. PREFIX
STD PRODUCT	DUAL POPPET PRV - VPA
CAGE CODE: 1PV08	
DRAWN BY: MAD	APPR. BY: BD

DRAWING TITLE	
DUAL POPPET PRESSURE RELIEF VALVE ICD	
DRAWING NO.	03629-001
DRAWN DATE: 08/28/18	SHEET 2 of 3
	REV. B

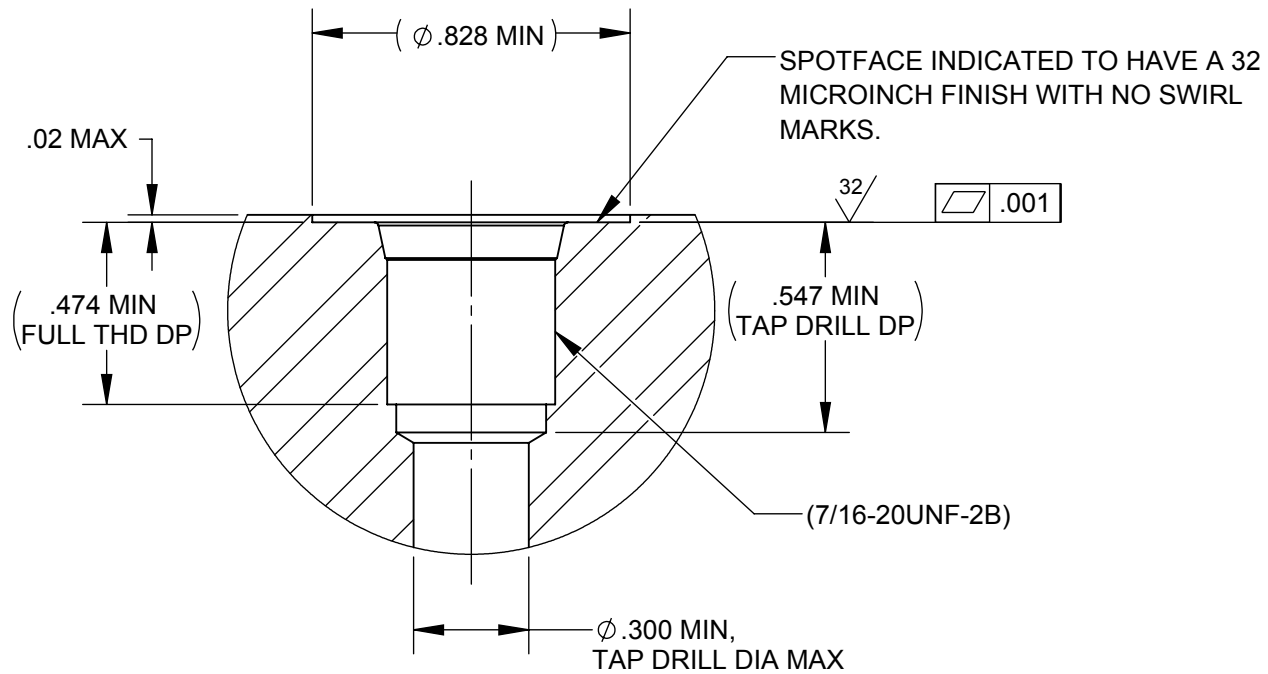

INSTALLATION DETAIL
STANDARD SAE #4 PORT PER SAE J1926
MODIFIED AS INDICATED ABOVE
USE PARKER TOOL #Y34732

PROPRIETARY NOTE All data and information contained or disclosed by this document is confidential and proprietary information of PREVCO Subsea LLC and all rights therein are expressly reserved. By accepting this material the recipient agrees that the material and the information therein is held in confidence and in trust and will not be used, copied, reproduced in whole or in part, nor its content revealed in any manner to others, except to meet the specific purpose for which it was delivered.	TOLERANCES UNLESS NOTED				PREVCO SUBSEA LLC		DRAWING TITLE DUAL POPPET PRESSURE RELIEF VALVE ICD	
	.X	.XX	.XXX	ANGLES	PROJECT	MODEL NO. PREFIX		
	$\pm .050$	$\pm .010$	$\pm .003$	$\pm .5^\circ$	STD PRODUCT	DUAL POPPET PRV - VPA		
	CONCENTRICITY .004 TIR				CAGE CODE: 1PV08		DRAWING NO.	03629-001
PRIMARY UNITS ARE INCHES				DRAWN BY: MAD	APPR. BY: BD	DRAWN DATE: 08/28/18	SHEET 3 of 3	REV. B