

NOTES, UNLESS OTHERWISE SPECIFIED:

1. ALL DIMENSIONS SHOWN ARE FOR REFERENCE ONLY.
2. WEIGHT: 7 OZ (ZINC), .2 OZ (Mg)
3. ORDER PART NUMBER 01420-001 FOR ZINC (STANDARD), OR 01420-002 FOR MAGNESIUM (OPTIONAL)

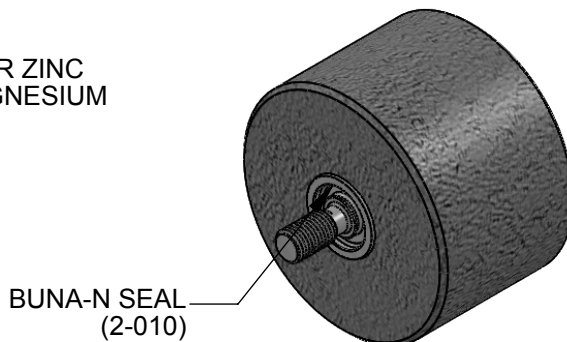

REVISIONS			
REV.	DESCRIPTION	DATE	APP.
A	INITIAL RELEASE	3-24-09	JAN
B	CORRECTED DRAWING NUMBER	10/6/10	JAN
C	CORRECTED WEIGHT IN NOTE 2	9/7/11	JAN
D	SHT 2: 10-32UNF-2B WAS 10-32UNC-2B	7/24/2017	BD

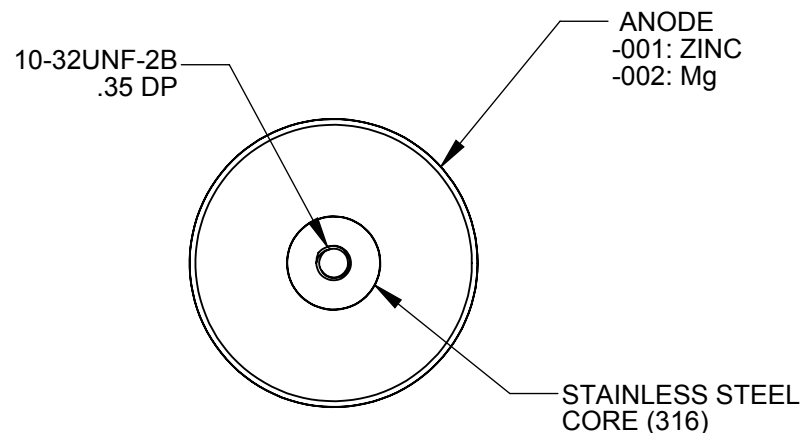
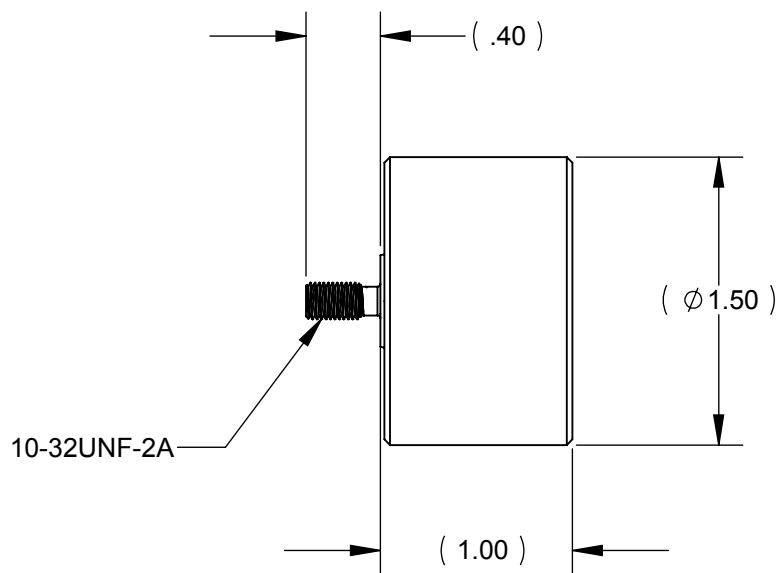

PROPRIETARY NOTE
 All data and information contained or disclosed by this document is confidential and proprietary information of PREVCO Subsea LLC and all rights therein are expressly reserved. By accepting this material the recipient agrees that the material and the information therein is held in confidence and in trust and will not be used, copied, reproduced in whole or in part, nor its content revealed in any manner to others, except to meet the specific purpose for which it was delivered.

TOLERANCES UNLESS NOTED			
.X	.XX	.XXX	ANGLES
±.050	±.010	±.003	±.5°
CONCENTRICITY .004 TIR			
PRIMARY UNITS ARE INCHES			

PREVCO SUBSEA LLC	
PROJECT	MODEL NO. PREFIX
GENERIC	STD PART
CAGE CODE: 1PV08	
DRAWN BY: VCE	APPR. BY: JAN

DRAWING TITLE	
ZINCROID INTERFACE DRAWING	
DRAWING NO.	01420-000
DRAWN DATE: 3-24-09	SHEET 1 of 2
	REV. D

