

NOTES, UNLESS OTHERWISE SPECIFIED:

1. ALL DIMENSIONS ARE NOMINAL AND SHOWN FOR REFERENCE.
2. HOUSING & POPPET MATERIAL; TITANIUM, GRADE 5 (6AL-4V).
3. FINISH: 1. TIODIZE OR EQUIVALENT COATING - 001  
2. NO COATING - 001NT
4. SPOTFACE INDICATED TO HAVE A 32 MICROINCH FINISH WITH NO SWIRLMARKS.
5. TORQUE TO 55-75 INCH-LBS.

REVISIONS			
REV.	DESCRIPTION	DATE	APP.
N	CHANGED NOTE 3	01/10/19	BD

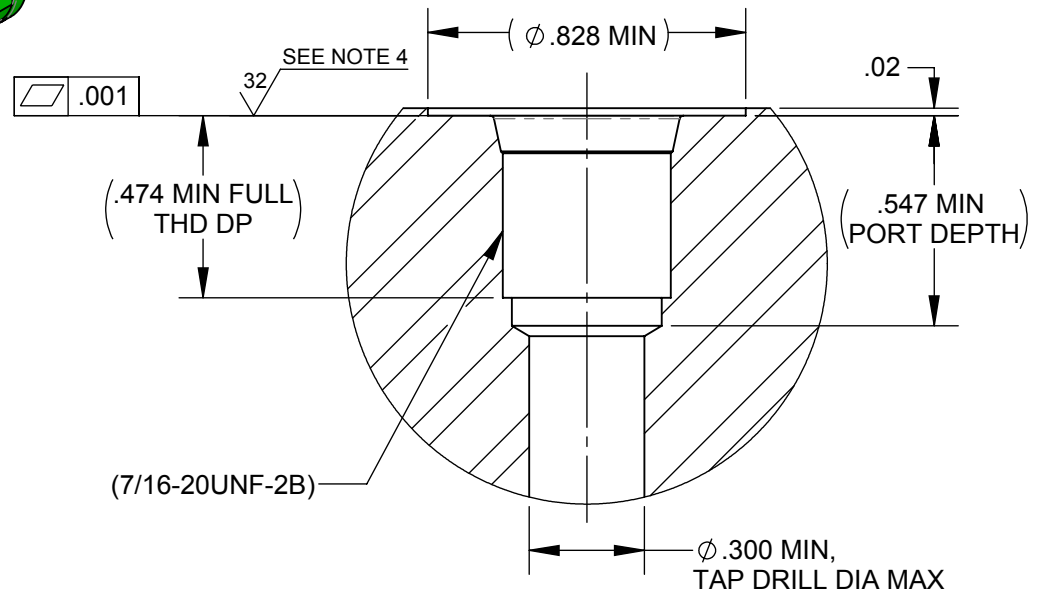
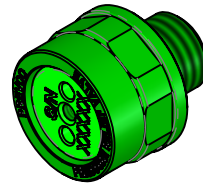
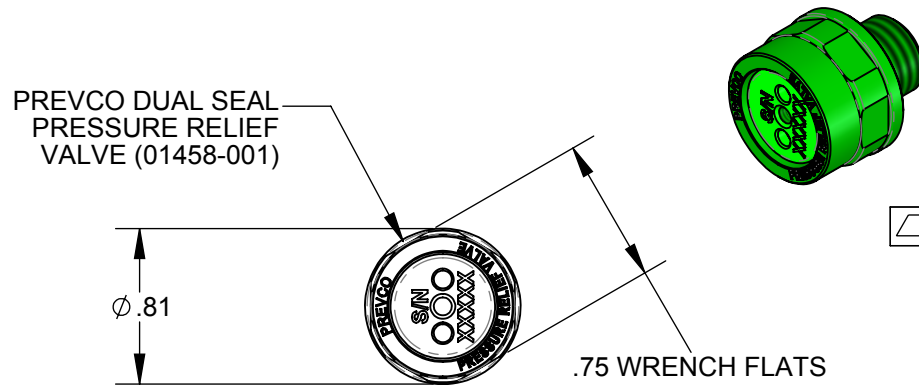

**DETAIL B - MOUNTING INTERFACE  
STANDARD SAE #4 PORT PER SAE J1926  
MODIFIED AS NOTED ABOVE  
USE PARKER TOOL #Y34732**

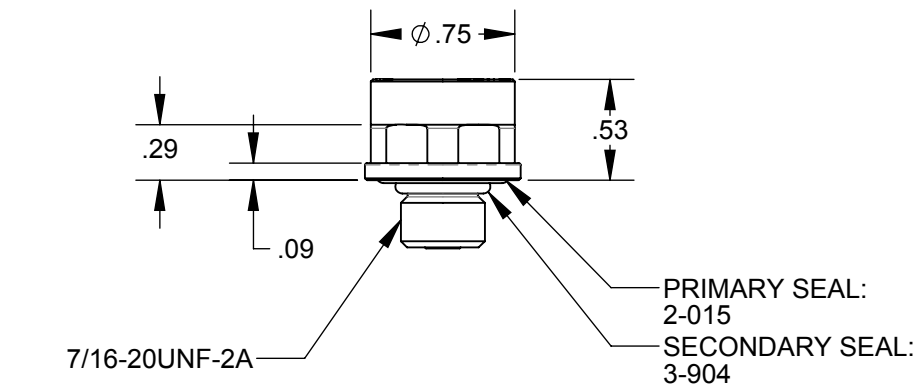

**PROPRIETARY NOTE**  
All data and information contained or disclosed by this document is confidential and proprietary information of **PREVCO Subsea LLC** and all rights therein are expressly reserved. By accepting this material the recipient agrees that the material and the information therein is held in confidence and in trust and will not be used, copied, reproduced in whole or in part, nor its content revealed in any manner to others, except to meet the specific purpose for which it was delivered.

TOLERANCES UNLESS NOTED			
.X	.XX	.XXX	ANGLES
$\pm .050$	$\pm .010$	$\pm .003$	$\pm .5^\circ$
CONCENTRICITY .004 TIR			
PRIMARY UNITS ARE INCHES			

<b>PREVCO SUBSEA LLC</b>	
PROJECT GENERIC	MODEL NO. PREFIX MOD 5
CAGE CODE: 1PV08	
DRAWN BY: VCE	APPR. BY: BD

DRAWING TITLE <b>DUAL SEAL PRESSURE RELIEF VALVE - 10 PSI ICD</b>	
DRAWING NO. <b>01104-001</b>	
DRAWN DATE: 11/14/17	SHEET 1 of 1
	REV. N