

NOTES, UNLESS OTHERWISE SPECIFIED:

1. ALL DIMENSIONS ARE PRELIMINARY AND SHOWN FOR REFERENCE ONLY.
2. "PACKAGING" DIMENSIONS DEFINE THE MAXIMUM PERMISSIBLE SIZE OF THE CUSTOMERS INTERNAL HARDWARE ASSEMBLY. THEY ARE NOT THE PHYSICAL DIMENSIONS OF THE HOUSING. PACKAGING DIMENSIONS INCLUDE CONSIDERATION FOR ASSEMBLY CLEARANCE, FABRICATION TOLERANCES AND HOUSING DEFLECTION AT MAXIMUM RATED DEPTH.
3. SEE PREVCO GENERIC HOUSING ASSEMBLY (00246-000) AND PROJECT BOM FOR ASSEMBLY DETAILS.
4. CUSTOMER SUPPLIED CONNECTORS NOT SHOWN.
5. INTERNAL ASSEMBLY HARDWARE NOT SHOWN.

REVISIONS			
REV.	DESCRIPTION	DATE	APP.
A	PRE-RELEASE FOR REVIEW	11/19/10	JAN

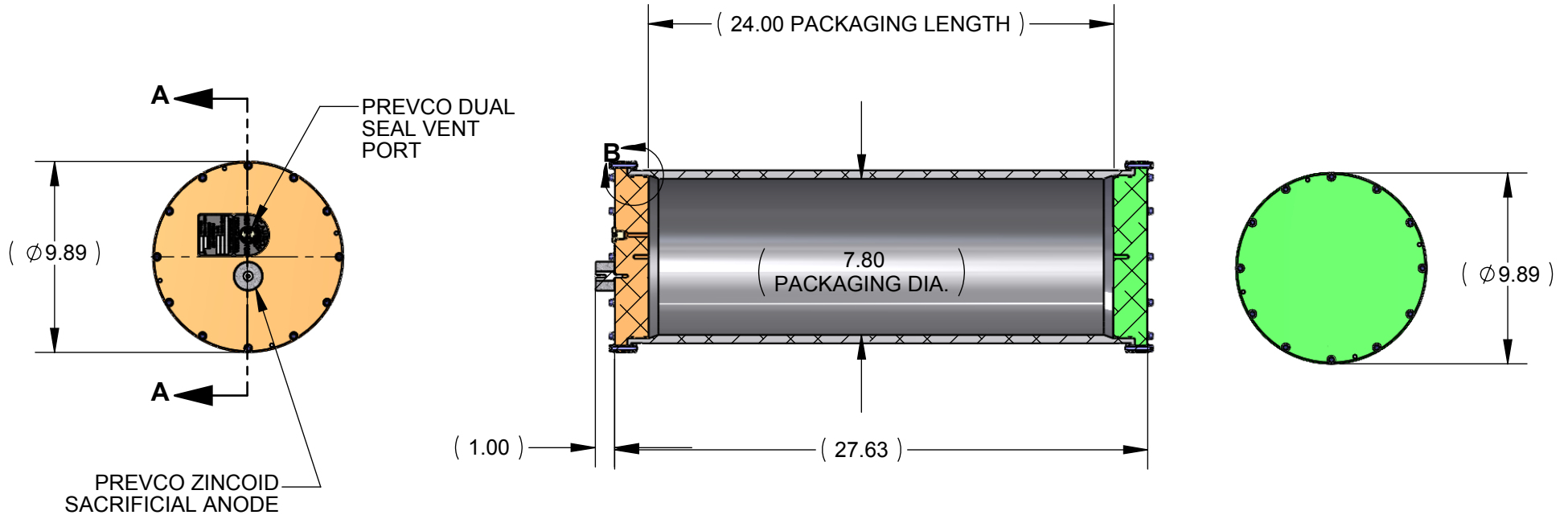
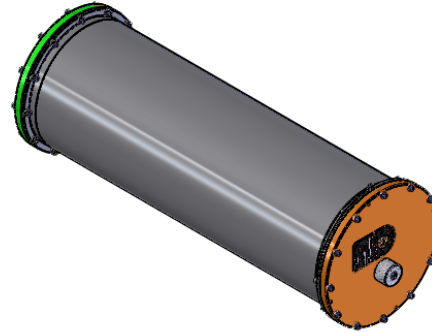

SECTION A-A

<p><b>PROPRIETARY NOTE</b></p> <p>All data and information contained or disclosed by this document is confidential and proprietary information of <b>PREVCO Subsea LLC</b> and all rights therein are expressly reserved. By accepting this material the recipient agrees that the material and the information therein is held in confidence and in trust and will not be used, copied, reproduced in whole or in part, nor its content revealed in any manner to others, except to meet the specific purpose for which it was delivered.</p>	TOLERANCES UNLESS NOTED				<p><b>PREVCO SUBSEA LLC</b></p> <p>PROJECT: PSXXXX MODEL #NO. PREFIX: A811SS(TB)-24</p>		DRAWING TITLE				
	.X	.XX	.XXX	ANGLES			HOUSING ASSEMBLY OUTLINE DRAWING				
	±.050	±.010	±.003	±.5°	DRAWING NO.		Q1704-010				
	CONCENTRICITY .004 TIR				DRAWN BY: VCE		APPR. BY: JAN		DRAWN DATE: 11/1/10		SHEET 1 of 2
PRIMARY UNITS ARE INCHES											

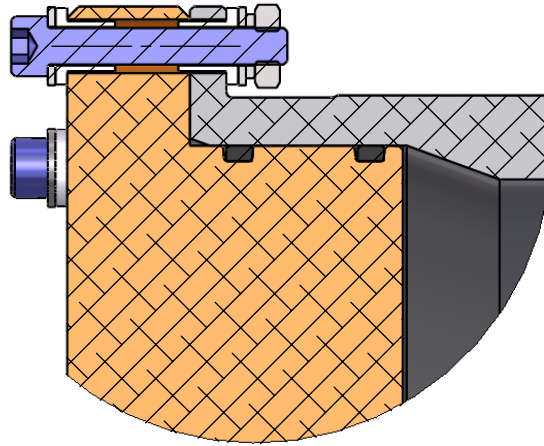

**DETAIL B**  
**SCALE 1 : 1**

<p><b>PROPRIETARY NOTE</b></p> <p>All data and information contained or disclosed by this document is confidential and proprietary information of <b>PREVCO Subsea LLC</b> and all rights therein are expressly reserved. By accepting this material the recipient agrees that the material and the information therein is held in confidence and in trust and will not be used, copied, reproduced in whole or in part, nor its content revealed in any manner to others, except to meet the specific purpose for which it was delivered.</p>	TOLERANCES UNLESS NOTED				<b>PREVCO SUBSEA LLC</b>		DRAWING TITLE		
	.X	.XX	.XXX	ANGLES	PROJECT	MODEL #NO. PREFIX	HOUSING ASSEMBLY OUTLINE DRAWING		
	±.050	±.010	±.003	±.5°	PSXXXX	A811SS(TB)-24	DRAWING NO.		
	CONCENTRICITY .004 TIR						Q1704-010		
PRIMARY UNITS ARE INCHES				DRAWN BY: VCE	APPR. BY: JAN	DRAWN DATE: 11/1/10	SHEET 2 of 2	REV. A	